



### Model Number

PMI14V-F112-2EPE2-IO

### Features

- Parameterization and diagnosis via IO-Link
- 3 configurable switching frames
- Measuring range 0 ... 14 mm
- Screened lead 2 m

## Technical data

### General specifications

Installation	flush
Object distance	max. 2.5 mm
Measurement range	0 ... 14 mm

### Nominal ratings

Operating voltage $U_B$	10 ... 30 V
Reverse polarity protection	reverse polarity protected
Linearity error	$\pm 0.3$ mm
Repeat accuracy R	$\pm 0.05$ mm
Resolution	33 $\mu$ m
Temperature drift	$\pm 0.5$ mm
No-load supply current $I_0$	$\leq 20$ mA
Operating voltage indicator	LED green

### Functional safety related parameters

MTTF <sub>d</sub>	490 a
Mission Time ( $T_M$ )	20 a
Diagnostic Coverage (DC)	0 %

### Interface

Interface type	IO-Link
Mode	COM 2 (38.4 kBaud)
Value range	0000h ... 7000h

### Switching output

Output type	2 Push-pull (4 in 1) outputs , 1 switch output PNP , short-circuit protected , reverse polarity protected , overvoltage protected , programmable
-------------	--

Operating current $I_L$	$\leq 100$ mA / output
Switching hysteresis	3-step, adjustable 0.2 m ... 0.8 mm
Voltage drop	$\leq 3$ V
Short-circuit protection	pulsing

### Ambient conditions

Ambient temperature	-25 ... 70 °C (-13 ... 158 °F)
---------------------	--------------------------------

### Mechanical specifications

Connection type	2 m PUR cable , screened
Housing material	diecast zinc, not laquered or coated
Degree of protection	IP67

Material	mild steel, e. g. 1.0037, SR235JR (formerly St37-2)
Target	
Note	The data relating to accuracy only apply to a distance to the object to be detected of 1 ... 2.5 mm.

### Compliance with standards and directives

Standard conformity	
Standards	EN 60947-5-2:2007 EN 60947-5-2/A1:2012 IEC 60947-5-2:2007 IEC 60947-5-2 AMD 1:2012 IEC 61131-9:2013

### Approvals and certificates

UL approval	cULus Listed, Class 2 Power Source, Type 1 enclosure
CCC approval	CCC approval / marking not required for products rated $\leq 36$ V

**Dimensions**

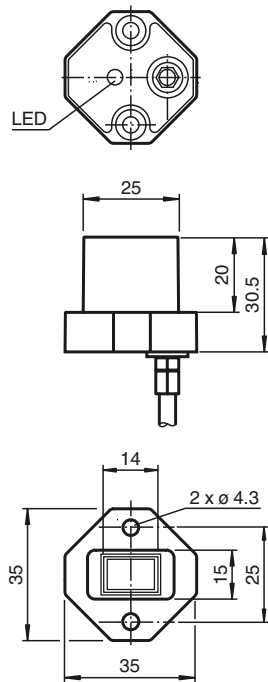

**Additional Information**

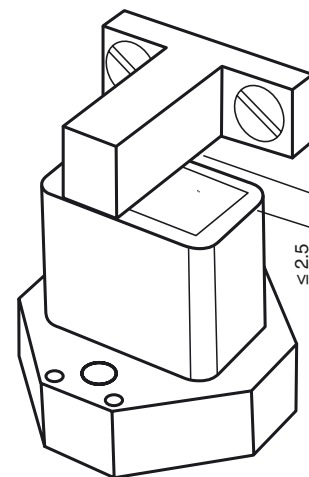
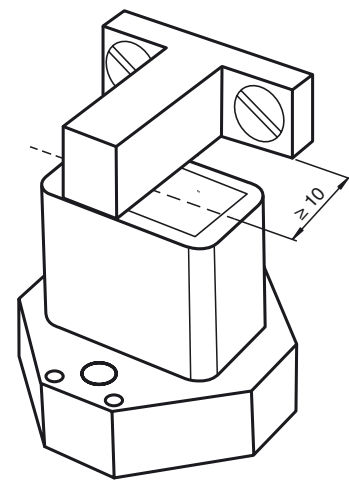
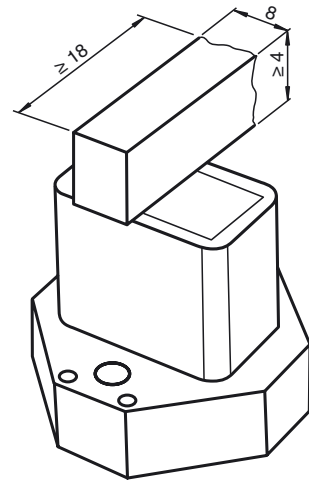

**Electrical Connection**

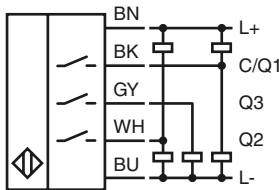

**Accessories**

**IO-Link-Master01-USB**

IO-Link master, supply via USB port or separate power supply, LED indicators, M12 plug for sensor connection

**IO-Link-Master-USB DTM**

Communication DTM for use of IO-Link-Master

**BT-F90-W**

Damping element for sensors of type F90, F112, and F166; side hole

**Description of Sensor Functions**

**Additional Functions and Parameters (IO-Link)**

<b>Additional functions</b>	Sensor temperature indicator Measuring range overrun and underrun indicator
<b>Measuring range</b>	Scalable measuring range Invertible measuring range
<b>Switching outputs</b>	Switching point can be parameterized/taught in Switching window can be parameterized/taught in Switching hysteresis can be parameterized Invertible switching output Selectable output type (high or low switched)

Release date: 2017-09-11 09:21 Date of issue: 2017-09-11 263758\_eng.xml

## Information on Installation and Operation

### Safety Information



Warnung

This product must not be used in applications in which the safety of persons depends on the function of the device.  
This product is not a safety component as specified in the EU Machinery Directive.

### Actuator

The linear position measurement system is optimally aligned to the geometry of Pepperl+Fuchs actuators.

### Using Your Own Actuators

Generally speaking, it is possible for you to use your own actuators. The specified measurement accuracy of the sensor will be achieved only if the actuator has the following properties:

- Material: construction steel such as S235JR+AR (previously St37)
- Dimensions (L x W x H):  $\geq 18 \text{ mm} \times 8 \text{ mm} \times \geq 4 \text{ mm}$
- The active surface of the actuator must protrude across the entire sensor width.

### Note:

The width of the actuator must be precisely 8 mm. If the width of the actuator deviates from this value, the position values will differ.

### Installation

- It is possible to flush mount the device.
- The distance between the center of the measurement field (framed area on the front panel of the sensor) and the fixing base or fixing elements (e.g., protruding screw heads) of the actuator must be at least 10 mm.

### Operating Instructions

The specified measurement accuracy is achieved if the distance of the actuator from the sensor surface is max. 2.5 mm.

### Definition of the Measuring Range/Measured Position

The measured position of the actuator is based on half of the width (center of the actuator).

The measuring range starts and ends when the actuator covers the measurement field marked on the sensor with half of its width in the course of its longitudinal movement.

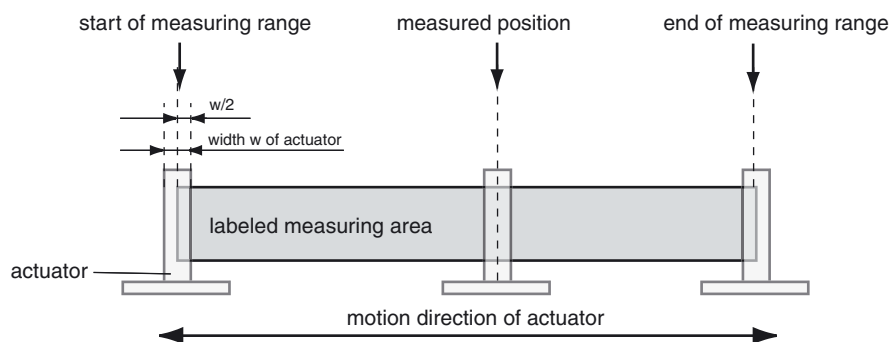

**Supported IO-Link device parameters**

Index	Subindex	Name
Smart sensor profile parameters		
0x3A		Teach-In Channel
0x3B		Teach-In Status
0x3C	1, 2	BD1_SPV, Switching signal 1
0x3D	1, 2, 3	BD1_SPV, Switching signal 1 configuration
0x3E	1, 2	BD2_SPV, Switching signal 2
0x3F	1, 2, 3	BD2_SPV, Switching signal 2 configuration
0x4000	1, 2	BD3_SPV, Switching signal 3
0x4001	1, 2, 3	BD3_SPV, Switching signal 3 configuration
Device specific operation parameters		
0x40	1, 2, 3	Centered Window Width
0x42	1, 2	AD_SPC, Analog signal setpoint value
0x43	1, 2, 3	AD_SPC, Analog signal configuration
0x5F	1, 2, 3, 4, 5	Measurement data collection
Standard operation control		
0x70	1, 2, 3, 4, 5, 6, 7, 8	Output configuration
0x74		Event configuration
0x7F		Locator indication control
User information		
0xC0		UT1, User tag 1
0xC1		UT2, User tag 2
Special function		
0xE2		Operating temperature
0xE8	1, 2	Device characteristics

Details of the listed device parameters can be found in the manual.